

Item No.: **MV732**

Applications

Perimeter and security lighting.
Ideal for loading platforms, barnyards, parking lots, rural homes, public entrances, off-street areas, or other commercial and residential applications.



Specification Features

- UL listed for wet locations
- Precision die cast aluminum housing with natural finish and UV-stabilized PS lens
- Aluminum reflector
- 21", 24" or 30" arm
- Dusk to dawn W/ twist-lock photo control
- Mounting hardware included
- Lampholder E-39, 4KV, UL approved
- Ideal for HPS 150 Watts and MV 175 Watts Max

Engineering Dimensions

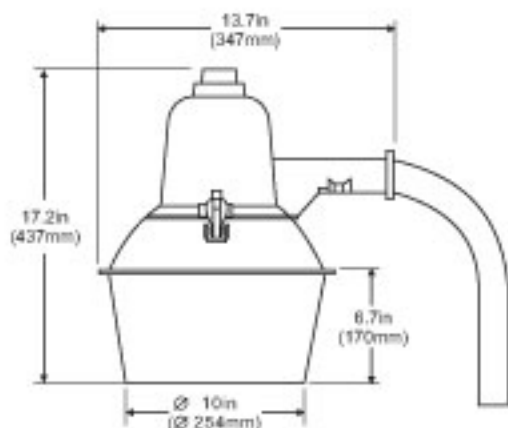

Line Drawing

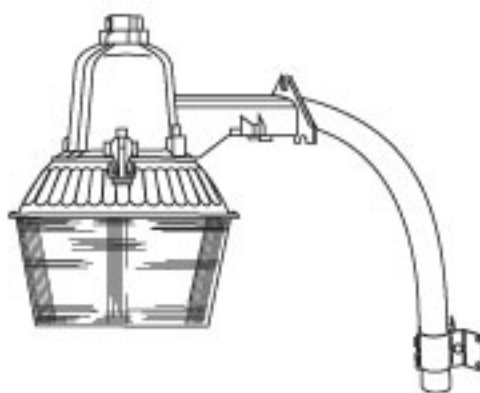

Packing Information

Weights	Cubit Feet	Master Carton Qty	40' Container Qty
11.86LBS	2.07'	1 PC	980 PCS

